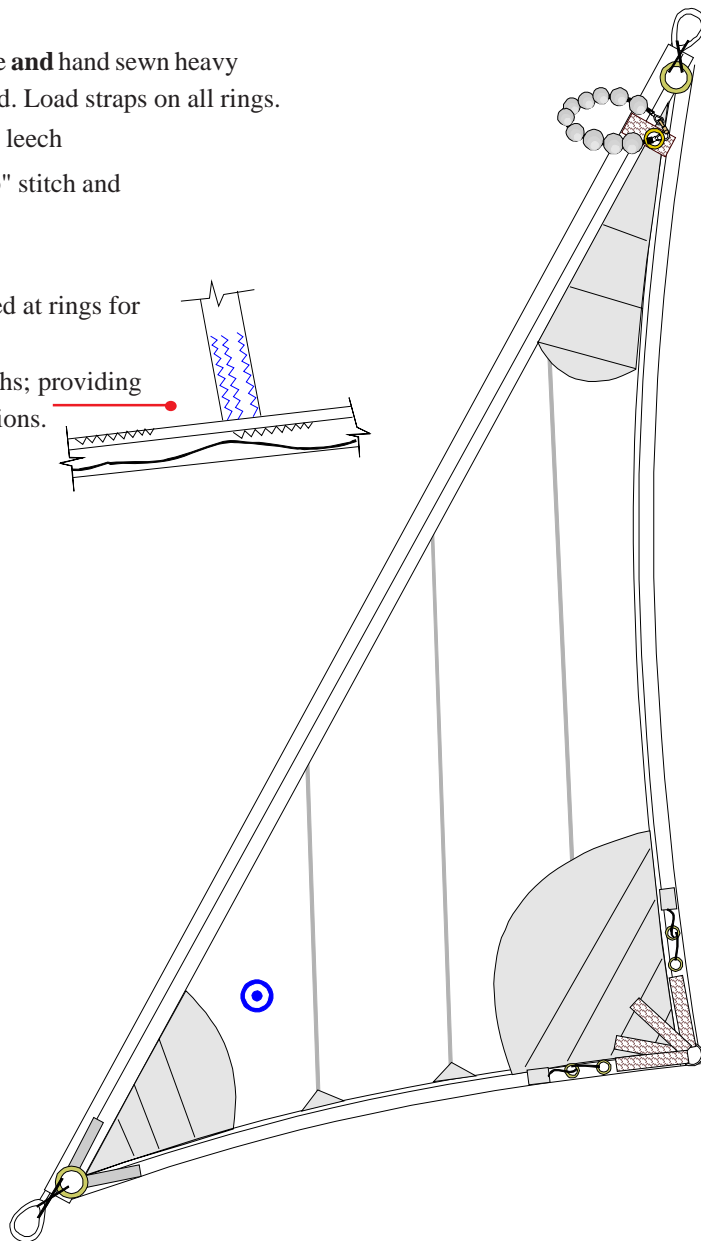
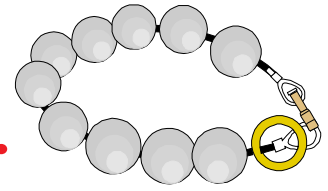

**TEMPEST - STORM JIB**

The Tempest Storm Jib is designed to be easily set and hoisted around a furled jib, providing cruising sailors with a safe and reliable way to carry a storm jib without the danger and work of removing the furling genoa prior to using this type of sail.

**Standard Features**

- ◆ Parrel Beads with stainless wire and 1.5" beads, fitted to a brass Jib-Hank for ease of attachment at Head
- ◆ Low Stretch Luff Rope
- ◆ Clew Ring Stainless Steel external ring with machine **and** hand sewn heavy duty nylon. Head/Tack Rings Stainless Steel Pressed. Load straps on all rings.
- ◆ Vertical cut to prevent cross-seams at highly loaded leech
- ◆ Seams extra wide and tripled stitched with a "3-step" stitch and V-138 U.V. resistant thread.
- ◆ Patches staggered block type.
- ◆ Polyester or Spectra Leech and Foot lines terminated at rings for secure reliable fastening.
- ◆ Double luff, leech and foot tapes of staggered widths; providing unparalleled durability in heavy air offshore conditions.
- ◆ Heavy Duty sailbag.

**Quality, Service, Value**

- ◆ Every sail we build comes with the assurance of a two year warranty of quality, service and value.
- ◆ If you ever need service, our consultants will direct you to the nearest of our worldwide network of Service lofts.
- ◆ No matter where in the world your sailing takes you, we are there to help.
- ◆ For further information, contact your Neil Pryde consultant or visit us at: <http://www.neilprydesails.com>