

Standard Features

- ◆ Half-moon reinforcement patches stitched and glued under each hank.
- ◆ Jib hanks attached to hydraulically pressed rings, bedded in a double wrapped 50mm heavy gauge webbing strap.
- ◆ Heavy duty brass piston hanks.
- ◆ Corner rings are Stainless Steel external rings with machine **and** hand sewn heavy duty nylon or Spectra load straps on all rings.
- ◆ Vertical cut to prevent cross-seams at highly loaded leech
- ◆ Seams extra wide and tripled stitched with a "3-step" stitch and V-138 U.V. resistant thread.
- ◆ Patches staggered block type.
- ◆ Polyester or Spectra Leech and Foot lines terminated at rings for secure reliable fastening.
- ◆ Double luff, leech and foot tapes of staggered widths; providing unparalleled durability in heavy air offshore conditions.
- ◆ Heavy Duty sailbag.

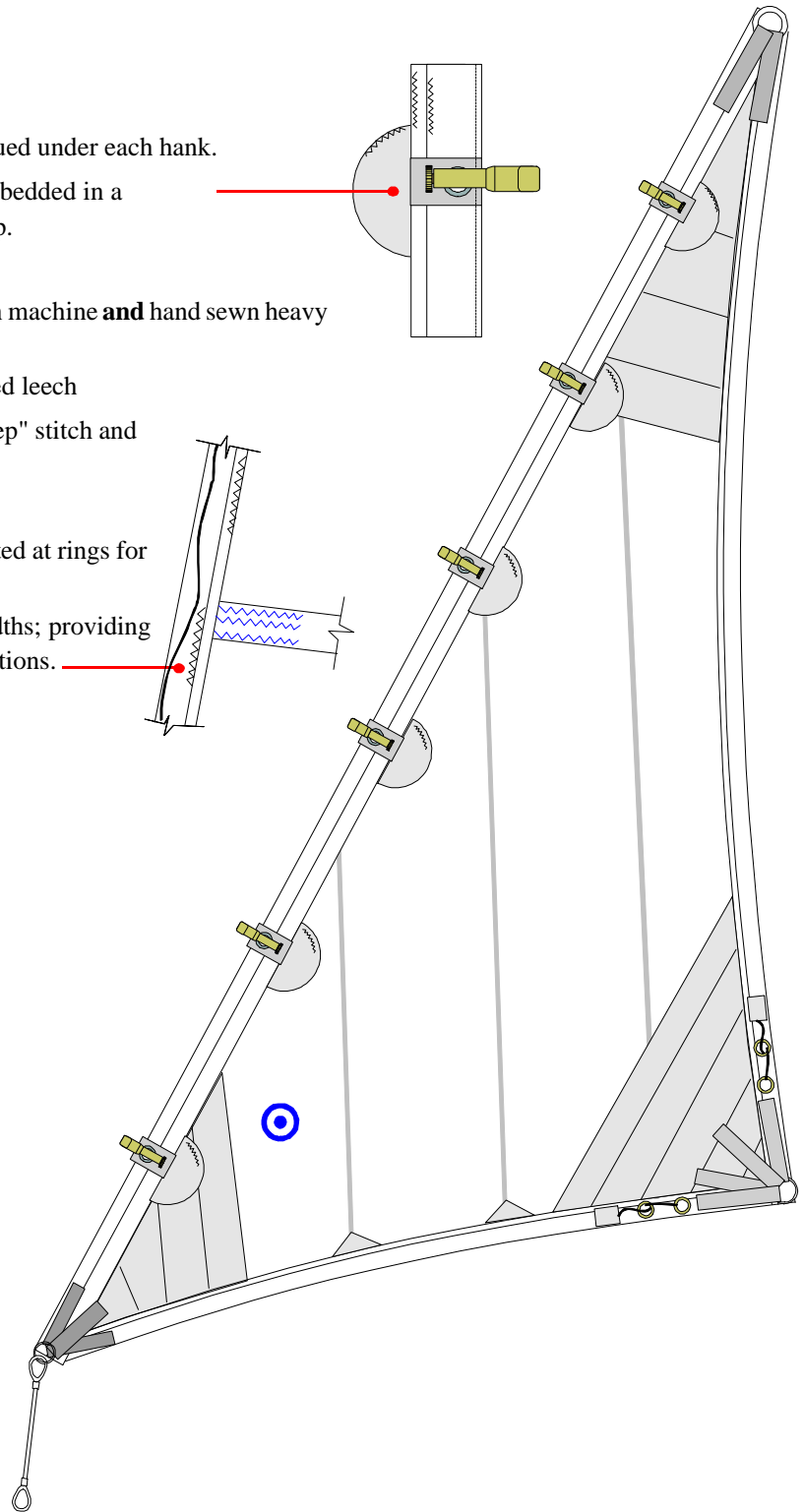

Quality, Service, Value

- ◆ Every sail we build comes with the assurance of a two year warranty of quality, service and value.
- ◆ If you ever need service, our consultants will direct you to the nearest of our worldwide network of Service lofts.
- ◆ No matter where in the world your sailing takes you, we are there to help.
- ◆ For further information, contact your Neil Pryde consultant or visit us at: <http://www.neilprydesails.com>

Standard Features

- ◆ Half-moon reinforcement patches stitched and glued under each hank.
- ◆ Jib hanks attached to hydraulically pressed rings, bedded in a double wrapped 50mm heavy gauge webbing strap.
- ◆ Heavy duty brass piston hanks.
- ◆ Corner rings are Stainless Steel external rings with machine **and** hand sewn heavy duty nylon or Spectra load straps on all rings.
- ◆ Vertical cut to prevent cross-seams at highly loaded leech
- ◆ Seams extra wide and tripled stitched with a "3-step" stitch and V-138 U.V. resistant thread.
- ◆ Patches staggered block type.
- ◆ Polyester or Spectra Leech and Foot lines terminated at rings for secure reliable fastening.
- ◆ Double luff, leech and foot tapes of staggered widths; providing unparalleled durability in heavy air offshore conditions.
- ◆ Heavy Duty sailbag.

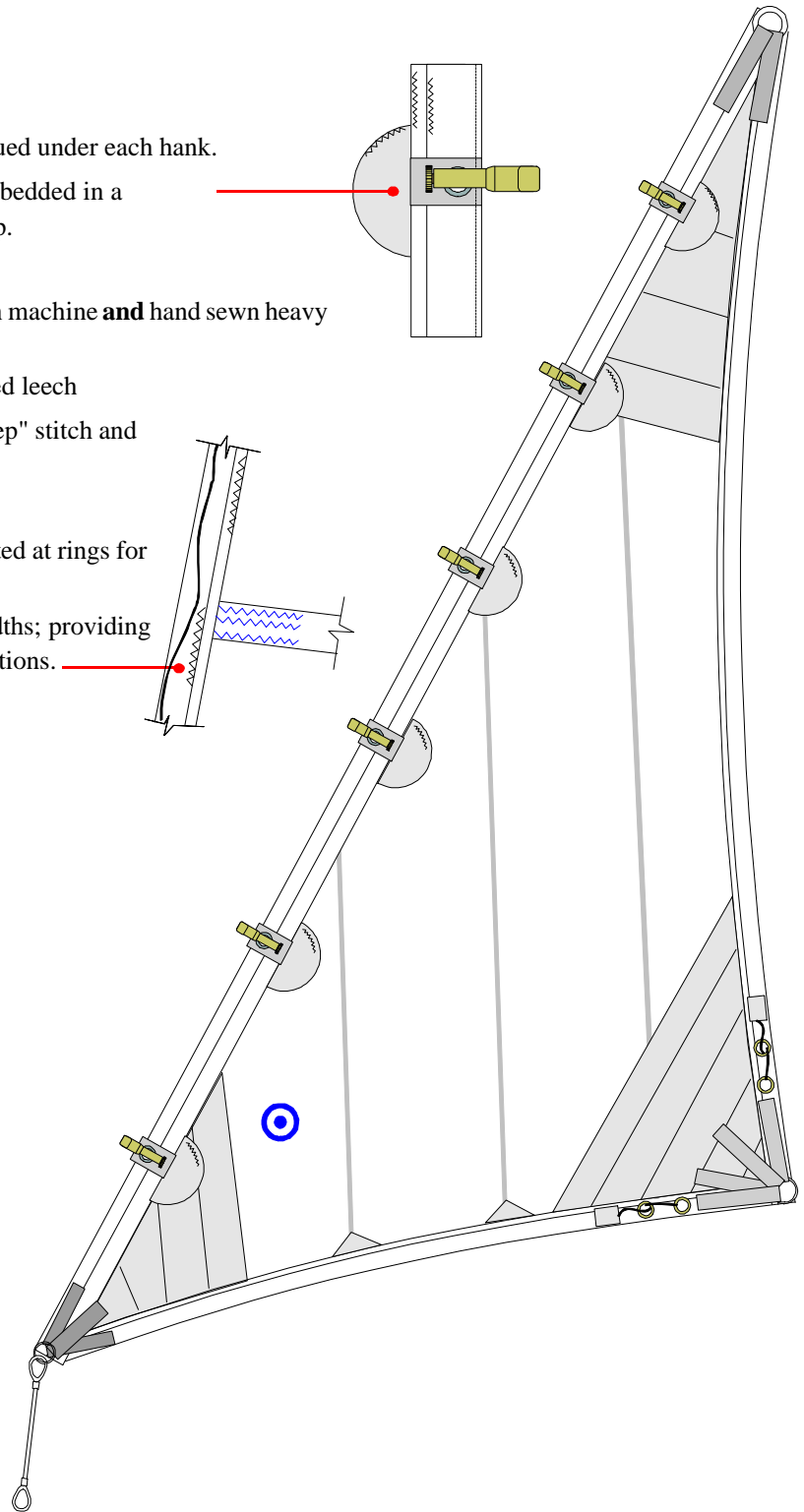

Quality, Service, Value

- ◆ Every sail we build comes with the assurance of a two year warranty of quality, service and value.
- ◆ If you ever need service, our consultants will direct you to the nearest of our worldwide network of Service lofts.
- ◆ No matter where in the world your sailing takes you, we are there to help.
- ◆ For further information, contact your Neil Pryde consultant or visit us at: <http://www.neilprydesails.com>