



INTERNATIONAL DESIGN AND TECHNICAL OFFICE

Sail Trimming Guide for the Beneteau 40

October 2007

© Neil Pryde Sails International
1681 Barnum Avenue
Stratford, CONN 06614
Phone: 203-375-2626 • Fax: 203-375-2627
Email: admin@neilprydesails.com
Web: www.neilprydesails.com

*All material herein
Copyright 2006-2007 Neil Pryde Sails International
All Rights Reserved*

HEADSAIL OVERVIEW:

The Beneteau 40 built in the USA and supplied with Neil Pryde Sails is equipped with a 140% headsail that is 408sf / 37.9m² in area and is fitted to a Profurl C430 furling unit.

The following features are built into this headsail:

- The size is optimized to sheet correctly to the factory track when fully deployed *and* when reefed.
- Neil Pryde Multi-Track Foam Luff System™, which allows for smooth and correctly shaped sails when reefed. ([See the Technical brief on our website for details on this system](#))
- Reef 'buffer' patches are fitted at both head and tack, which are designed to distribute the loads on the sail when reefed.
- Reefing marks located on the starboard side of the tack buffer patch provide a visual mark for setting up pre-determined reefing locations. These are located 660mm/2.17' and 1320mm / 4.33' aft of the tack.
- A telltale 'window' at the leading edge of the sail located about 14% of the luff length above the tack of the sail and is designed to allow the helmsperson to easily see the wind flowing around the leading edge of the sail when sailing upwind and close-hauled. The tell-tales are red and green, so that one can quickly identify the leeward and weather telltales.
- A draft stripe for quick sail shape/depth reference.

There are several points to consider:

- We used the outer shroud where it intersects the deck at the aft side of the shroud as our 'zero' point in measuring the car location aft along the track. To ensure accuracy we suggest measuring both sides when determining the location of the cars.
- The forward end of the car has a lever that is lifted up to disengage the pin that holds the car in place. When moving the car, always move the 'lazy' sheet, so that there is no load on the jib sheet or car when making adjustments. Lift the pin and slide the car forward or aft.
- There are evenly spaced holes on the genoa track fore and aft and on 100mm centers. The adjustment pin of the car will lock into these holes.
- Our measurements correspond to marks at the forward end of the car.

Why Mark The Lead Position:

You will find that once the initial trim settings are made to the genoa lead (car) position (which is critical to good performance) the cars will not require much movement fore and aft for different conditions. However, as one reefs the headsail smaller and smaller, the sail moves forward and the clew elevates slightly as a result. This changing dynamic requires that the genoa lead position be adjusted to ensure proper trim when sailing with this now smaller sail. In marking the location of the cars so that they coincide with the reefing marks at the tack of the genoa you will take the guesswork out of setting the leads when reefing. The lazy genoa car can quickly and easily be moved forward to the pre-marked location and then during a slow tack the genoa is reefed to the coinciding mark at the tack. The sail trim will be properly set on the new tack. When measuring the lead positions (as described below) you need to mark the track at the forward edge of the genoa car. You can do this with permanent marker, tape or some sort of self-adhesive 'dots'. The marks should be on the deck as track mounted tape/marks can be rubbed off by the car.



Measuring aft from the shroud base

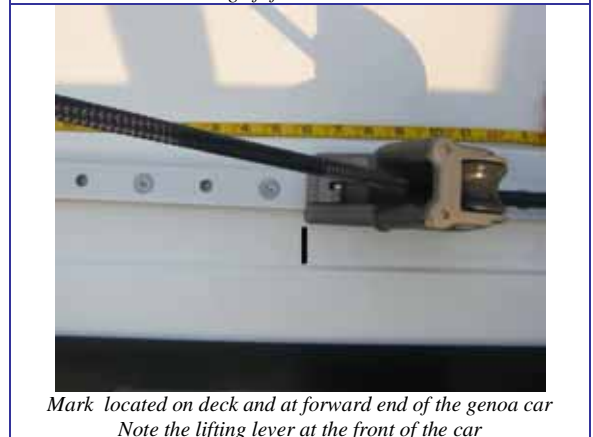

*Mark located on deck and at forward end of the genoa car
Note the lifting lever at the front of the car*

MARKING THE LEAD POSITION:

Full Size:

When your genoa is completely unfurled for sailing, the forward edge of the genoa car should be 5'-9" / 1765mm aft of the outer shroud. This will be your 'all-purpose' lead position. See picture to middle right.

- This will be appropriate for wind strengths of 7-12 knots true wind.
- Sailing in less than 7 knots of true wind move the lead position forward to 5'-6"/1676mm aft of the shroud, making the genoa more powerful for these conditions.
- In more than 12 knots of wind, you may move the lead aft one hole (de-powering the sail slightly) or begin to consider reefing the headsail.
- The genoa should be sheeted so that there is sufficient tension on the sail to bring the leech to between 2"-6" / 50-150mm from the tip of the lower spreader and the sail should be between 3"-6" / 75-150mm outside the shroud base. The sail will be inside the upper spreader as shown in the photo at right.

First Reef Mark:

With the genoa furlled to the first 'reefing' mark just aft of the tack of the sail, the lead car should be moved forward until it is 4'-2"/1267mm aft of the outer shroud. The leech will be just aft of the spreader as shown below. Note that the leech of the sail should still be equidistance from the shroud base and where it intersects the outer shroud.

Second Reef Mark:

With the genoa furlled to the second and deepest 'reefing' mark, the lead car should be moved forward until it is 2'-2"/658mm aft of the outer shroud. Conditions that require this third reef will be quite windy and depending on your comfort level may be put in place anywhere from 16 knots on up. This position will keep the foot of the sail quite tight, flattening the shape for good breezy performance.

Genoa Notes:

Generally, sail trim is a bit of science, a bit of feel and a bit common sense. As a basic rule, we like to say *that if it looks right, it probably is*. Your Neil Pryde sails are designed, tuned, and tested for each specific model and as such, you will be able to achieve proper trim using this guide.

Occasionally, you might find that the leech flutters a bit. If this happens, it's usually that the sheet tension is not tight enough (you need to winch the sail in a bit tighter). However, if the boat becomes over-powered (healing excessively), you should consider reefing the sail at this time. Assuming you have the leads in the right location and the sheet tension is correct, but the sail still has a bit of flutter, you should adjust the leechline to keep the leech from fluttering.

The first photo shows the leechline pocket opened to reveal the leechline, snubbing eyes, cleat and the 'tail' pocket. The snubbing eyes help to take the load from the line making cleating and un-cleating an easy task. The 'tail pocket is on the inside of the leechline cover and you can put the excess leechline tail into this pocket before closing the cover. To adjust, take up the line by pulling downward just above the eyelets, taking up the slack in the line just below the cleat. Pull the line until the flutter stops. Cleat the line and insert the tail into the pocket and close the flap.



Leech trim, closed hauled and with full size sail



Track location with at "Light Air" setting and standard setting just aft.



Car location when reefed to second mark.

Reefing Notes:

Reefing the mainsail, headsail or both in combination allows the skipper to keep the trim of the boat in a more upright mode. This is a safer, more comfortable and faster way to sail in strong breezes. In addition, reefing the sails importantly affects the balance of the boat and can increase or decrease the amount of weather helm that develops at the wheel. The timing and sequence of reefing is up to the skipper of the boat to consider and will vary from skipper to skipper, as some conditions or preference in how the boat is sailed in reefing conditions are variable. With this in mind, the following points are general observations.

1. The 'balance' of helm is regulated through mast rake, fore and aft. This will be preset during the initial commissioning.
 - a. More mast rake aft will move the sailplan center of effort aft, in effect putting more loads on the sails aft of the keel. This will then in turn 'pivot' the boat around the keel, bringing the bow into the wind.
 - b. Mast rake forward and the opposite is true, the balance moves forward and the boat will gain neutral or lee helm.
2. Weather helm is desirable in all sailing yachts. It keeps the bow into the wind while sailing upwind and improves your VMG to weather.
 - a. In 10 to 12 knots of wind with the sails fully deployed we expect to have the helm just slightly above neutral or with a small amount of helm. This means in releasing the wheel, the boat will (depending on wind, sea conditions and boat trim) slowly come into the wind.
3. As you reef the sails, you are also going to affect the balance or center of effort on the sailplan.
 - a. Reefing the genoa will reduce the area of this sail and in turn moves the center of effort aft, increasing helm.
 - b. Reefing the mainsail first, will move the center of effort forward and decrease the weather helm.

With these points in mind, we generally recommend that in the case of the B40, the mainsail should be reefed to the first reef in the classic mainsail or just before the top-most batten with the PBF mainsail (both giving about an equal area reduction) when first shortening sail. This will ensure a balanced helm as the breeze initially builds. In 15 knots true wind, you will need the mainsail reefed and the genoa reefed to the first reef mark and though you may be somewhat underpowered initially, as sailors we find it safer to assume the wind will continue to build and it is always more prudent to reef earlier than later. Should the wind decrease, increasing the sail area is easily accomplished by deploying the genoa so it can be full sized again.

Assuming the breeze continues to build into the upper teens, it is important to have a sense of how much weather helm you have. If you find yourself fighting to keep the bow down (the boat continually wanting to come up hard into the wind) then you need to reduce the mainsail area either by furling the mainsail in-mast additionally or going to the second reef in the Classic mainsail. This will establish the balance back to the helm and also decrease the total net area, making the boat more upright and comfortable.

1. Furling mainsails offer the user infinite reefing positions as compared to fixed reefing points found on traditional mainsails. The only exception to this is that when reefed the sail should not be reefed with a batten partially in or out of the mast. Reefing points should be on either side of a batten for best results.
2. Typically reefing the mainsail so that the uppermost batten is just behind the mast will reduce the area of the mainsail by 30-35%, reefing to the second highest batten will reduce the area by 65-75%. (this compares to 25 and 45% on the Classic mainsails)
3. Given this reduction, we recommend a starting place for the first reef to be about three quarters of the way to the uppermost batten and the second reef half way between the uppermost and second batten. These of course will be variable as outlined in the paragraphs above.



Leechline, cleat and 'tail' pocket

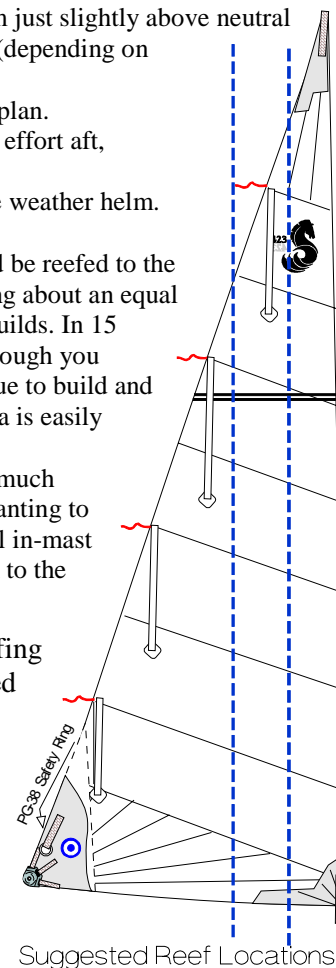

MAINSAIL TRIM:

The following points on mainsail trim apply both to the Furling and Classic mainsail, as the concepts are the same. Mainsail trim falls into two categories, upwind and downwind.

Upwind

1. Upwind in up to about 8 knots true wind the traveler can be brought to weather of centerline. This ensures that the boom will be close centerline and the leech of the sail in a powerful upwind mode.
2. The outhaul should be eased 2" / 50mm at the stopper, easing the foot of the mainsail away from the boom about 8"/200mm
3. Mainsheet tension should be tight enough to have the uppermost tell tail on the leech streaming aft about 50% of the time in the 7-12 true wind range. For those with furling mainsails the action of furling and unfurling the sail can play havoc with keeping the telltales on the sail and you may need to replace them from time to time.
You will find that the upper tell tail will stall and fold over to the weather side of the sail about 50% of the time in 7-12 knots. However, if the top tell tail is folding over to leeward, the mainsheet tension is too loose and it needs to be brought in tighter.
4. In 8-12 knots the outhaul should be brought in ½ of light air setting and the traveller lowered to half the distance to centerline.
5. With the mainsheet tension set, the boom-vang should be tensioned until it is just snug.
6. In over 12 knots, the upper tell tail should be flowing almost all the time.
7. As the wind builds above the 12-knot range you will need to de-power the boat to keep her on her lines and to reduce weather helm. Start by getting the outhaul all the way on and then let the traveler down in additional 3" /76mm increments until the boat balances. If the action of lowering the traveler to balance the helm causes the mainsail to backwind, this means it is time to consider reefing the mainsail.



Downwind

1. With the boom-vang set as outlined above the mainsail will have close to the right trim for downwind sailing.
2. As soon as the sails are eased and sailing lower downwind angles (even as little as 3⁰) ease the traveler down in 3" increments until the boat balances and drives well.
3. Bearing off 12⁰ and deeper, the traveler should be all the way out and at this point start to ease the mainsheet. The leech tension should correct assuming the boom-vang was tightened as above. At this point all your telltales will be flowing aft.
4. With a battened mainsail (Classic), one normally keeps the top batten parallel to the boom while off the wind. Achieve this with the boom vang keeping the leech adjusted and the telltales flowing aft. Obviously, without the battens (furling mainsails) you will need to eyeball it. If the top batten or sail is falling off to leeward from this position, tighten the vang to bring it back in line with the boom.
With the leech trimmed this way, both tell tails should fly aft 95% of the time.

SAIL CARE:

Both mainsails and headsails will get dirty with time and use. A primary source is air pollution which deposits filth on the standing rigging. The sails in turn will pick this up when they come in contact with shrouds, mast and spreaders. This obviously affects the headsail to a greater degree as it is dragged across the rigging with each tack and gybe. We recommend a yearly cleaning either on your own or through a commercial sail cleaner or sail loft.

Roller Furling Mainsails are equipped with a small label on the starboard clew of the sail. This is designed as a 'marker' that will indicate when the mainsail is furled inside the mast enough so that the U.V. cover on both sides of the sail will protect the sail. It is imperative that the sail be furled so that the label is clearly inside the mast, thus protecting the sailcloth from harmful U.V. which will damage the sailcloth quickly.



Furling Label on starboard side of mainsail clew patch



Mainsail with label and sail exposed; INCORRECTLY furled



Mainsail with label furled inside mast and sail furled correctly.